



## UNI-SPAN®

APC Uni-Span® is a strong and durable type of longspan shelving unit, suited to the storage of large, heavy loads.

Capable of carrying loads up to 400kg per shelf this system offers a robust storage option that creates space in any workplace. It is fast and easy to assemble and can be reconfigured at any time.

[apcoffice.com.au](http://apcoffice.com.au)



## **ABOUT APC**

**At APC, we provide efficient and flexible storage solutions for ever evolving office space designs and commercial applications.**

As an Australian owned, designer and manufacturer based in Perth, we have been providing bespoke storage solutions for contemporary interiors since 1972. Catering to commercial, corporate, government, and public sector markets.

Our current storage range consists of high end Aislesavers (mobile shelving systems), Uni-Shelf (open shelving), mobile pedestals, tambour cabinets, mobile caddys, purpose built lockers and bespoke storage units.

Service is what we focus on, however it's the product, the most relevant, best-designed, world-class storage solutions that we provide.



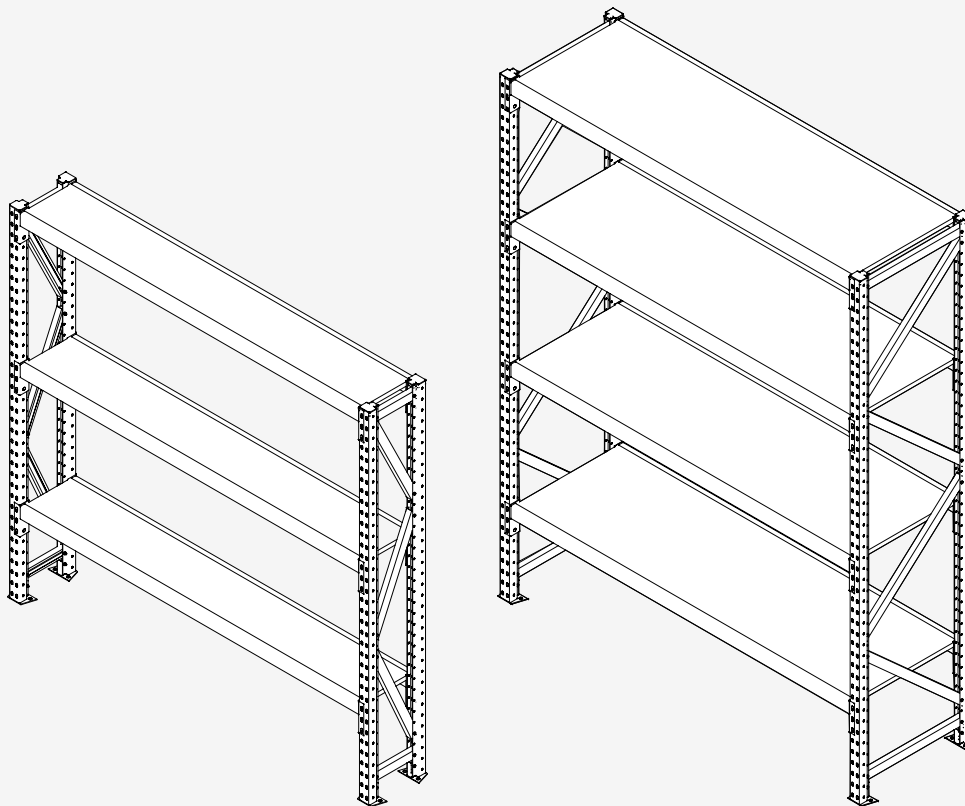

## TECHNICAL SPECIFICATION

Due to the versatility of the product, APC Uni-Span® is available in various combinations with reference to the sizes below.

HEIGHT	WIDTH	DEPTH
1800mm	1200mm	450mm
2100mm	1800mm	600mm
2400mm	2400mm	840mm

**10**  
YEAR  
WARRANTY

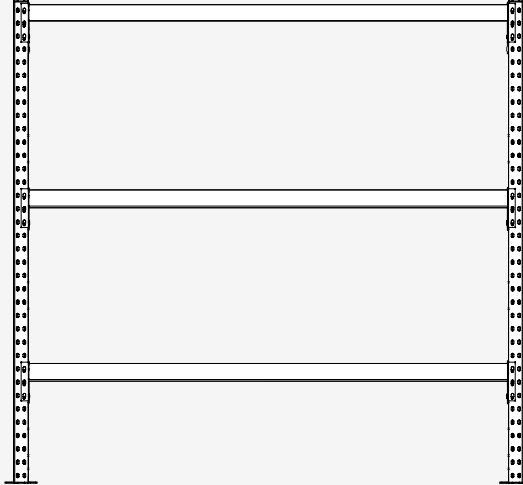

1800H x 1800W

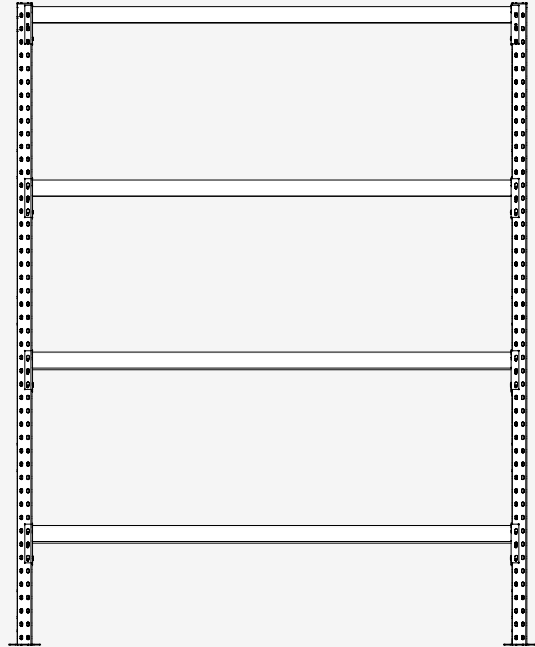

2400H x 2400W

**Features:**

- ▶ Shelves are easily adjustable in 50mm increments
- ▶ Can be joined to form a continuous run of shelving
- ▶ Various shelf inserts available

**Stock Colour:**

Cyber Grey (CG)



## ACCESSORIES

Our range of accessories is only limited by your imagination. These accessories provide different ways of ensuring that you get the most out of our longspan shelving range.

We're constantly looking for new ways of adapting our product to suit our customer base. If you don't see what you're looking for, just let us know!

- ▶ Cover panel
- ▶ Hanger rail
- ▶ Mesh shelf insert
- ▶ Steel shelf insert
- ▶ Melamine shelf insert
- ▶ End frame cover panel
- ▶ Extra shelves

ISO 9001  
AS/NZS 4801  
OHSAS 18001  
ISO 14001

BUREAU VERITAS  
Certification



## QUALITY & ENVIRONMENTAL CONTROL

APC has developed and implemented an Environmental Management System (EMS) that not only ensures legislative awareness and compliance, but gives us the ability to identify cost savings with greater emphasis on “resource, waste and energy management” minimising our environmental footprint.

Customers can be confident that APC’s strong EMS gives us the structured framework to quantify, monitor and control the impact of our operations on the environment, now and in the future.

APC also has a Quality Management System (QMS) focused on maintaining consistently impeccable customer service to our clients, along with the delivery of quality products and services that meet international standards. Our mature QMS provides us with “quality” systems, “quality” staff and the customer with a guaranteed “quality” product.



## COLOURS

Our stock colour range is a refined selection that will always have the shortest lead times.

If you are looking for a customised appearance for your office environment, we offer a large range of colour options to suit your needs.

For the full range of colour options, please refer to the latest version of the Dulux powdercoating range.

Please note: Custom colouring is only available for orders over a certain quantity.





**New South Wales**

6 Foundry Road,  
Seven Hills NSW 2147

**Victoria**

85 Proximity Drive,  
Sunshine West VIC 3020

**Queensland**

72-74 Nestor Drive,  
Meadowbrook QLD 4131

**Western Australia**

4 Hanwell Way,  
Bassendean WA 6054

**P: 1300 138 303**

**[apcoffice.com.au](http://apcoffice.com.au)**